

Slimline, low glare linear luminaires

Flexbar is an elegant surface mounted, suspended or recessed linear luminaire ideal for a wide range of applications. The high performance lens technology provides well-controlled low glare lighting for optimum user comfort.

Individual and continuous versions along with corner joints allow the lighting designer to be creative with their lighting layouts. Supreme efficiency (160.5 LL/CW) and 100,000 hour life ensures Flexbar has the performance to match its elegance.

Applications: offices, teaching spaces, meeting rooms, breakout areas, reception areas, circulation spaces and retail.

- Integral through wiring system with plug and socket connector versions
- TM66 score of 2.6 - LIA/CIBSE certification scheme TSD-012 verified
- White (RAL 9016) or black (RAL 9005) body finishes
- Black 'invisible' light source, metallised low glare and white reflector options
- Versions with optional uplight component
- Surface, suspended and recessed mounting options
- Magnetic clip-in light engine
- Low glare optics for EN12464-1 / LG7 (<math><1500\text{cd/m}^2 @ 65^\circ</math>) when using the metallised or black reflector

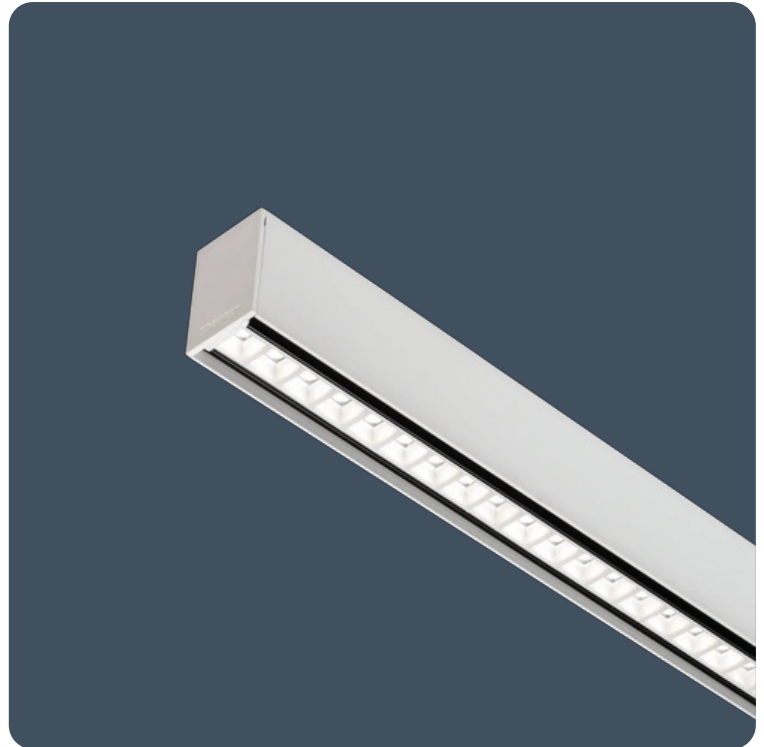

Notes: See installation leaflet for fixing locations

Up to IP40

Up to 160.5 LL/CW

TM66 circularity score 2.6

Specification

Mounting	Recessed Surface Suspended	IP rating	Up to IP40
Nominal size	850 x 870 mm 1400 mm 2800 mm	Max presence detection height	8 m

Sustainability

TM66 circularity score	2.6
------------------------	-----

Lighting

Lumen output	1,195 lm - 10,710 lm	Efficacy	Up to 160.5 LL/CW
--------------	----------------------	----------	-------------------

Emergency data

Emergency lumen output	345 lm - 440 lm	Emergency type	Maintained
Emergency duration	3 hours	Battery specification	Nickel Metal Hydride (NiMH)

Power

LED power	8 W - 63 W	LED power per metre	6 W - 22 W
Circuit power	10 W - 71 W		

LED characteristics

CRI	80+	Colour temperature	4000 K
Rated life (hours)	100 K - L80/B10		

Compliance

UKCA	Yes	CE	Yes
Energy efficiency class	This product contains a light source of energy efficiency class B	Thermoplastic rating	TP(a)

Dimensions

Suspended version

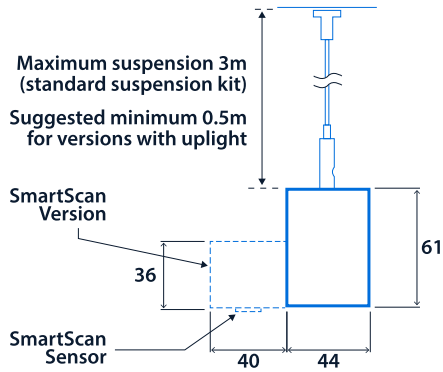

Surface version

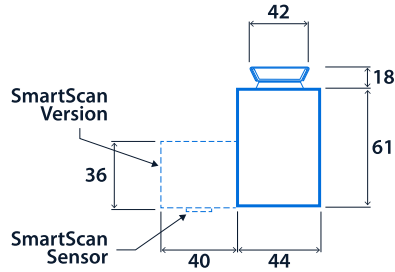

Recessed version (pull-up only)

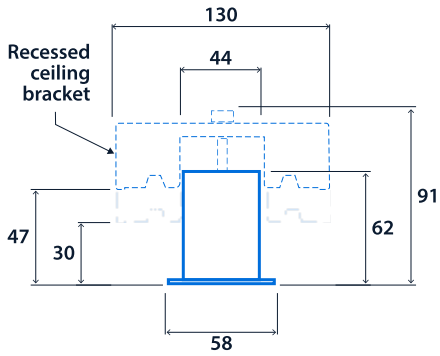

Mounting Arrangement - Plasterboard ceiling

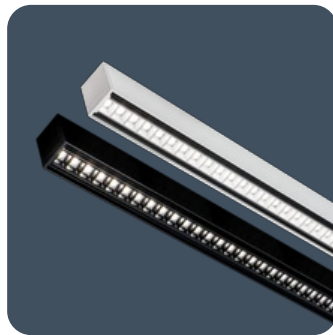
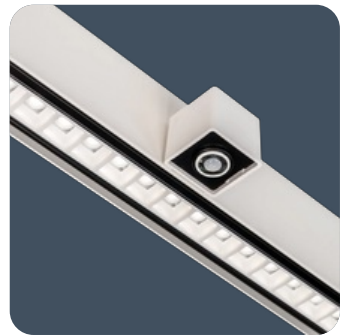
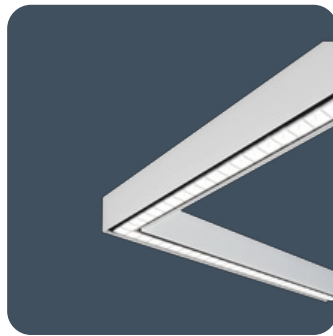
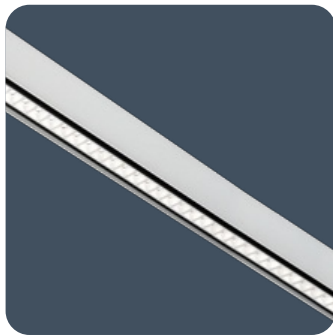
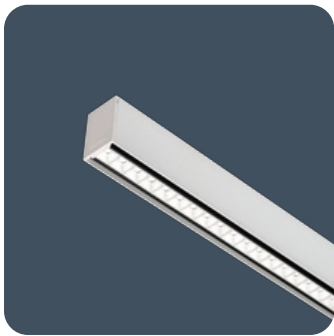
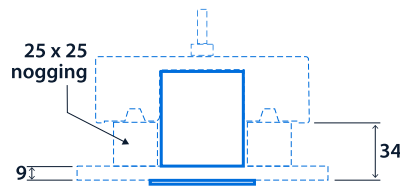



Click or scan here
View Flexbar variants using
our online filtering tool



Information is correct as of 12 Mar 2025, however must not be interpreted as a guarantee of individual product performance and/or characteristics. We reserve the right to alter specifications and designs without prior notice.